

FORT

USER MANUAL • MANUAL DE USUARIO • MANUEL DE L'UTILISATEUR
BENUTZERHANDBUCH • MANUALE D'USO • MANUAL DO USUÁRIO

**x5**

Cable ties
 Bridas para cables
 Colliers de serrage
 Kabelbinder
 Fascette per cavi
 Abraçadeiras

**x4**

Screw #6-32 5mm
 Tornillo #6-32 5mm
 Vis #6-32 5mm
 Schraube #6-32 5mm
 Vite #6-32 5mm
 Parafuso #6-32 5mm

**x4**

Screw #6-32 6.5mm
 Tornillo #6-32 6.5mm
 Vis #6-32 6.5mm
 Schraube #6-32 6,5 mm
 Vite #6-32 6,5 mm
 Parafuso #6-32 6.5mm

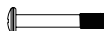
**x8**

Screw M3 28mm
 Tornillo M3 28mm
 Vis M3 28mm
 Schraube M3 28mm
 Vite M3 28 mm
 Parafuso M3 28mm

**x20**

Screw M3 5mm
 Tornillo M3 5mm
 Vis M3 5mm
 Schraube M3 5mm
 Vite M3 5mm
 Parafuso M3 5mm

**x2**

Screw #6-32 10mm
 Tornillo #6-32 10mm
 Vis #6-32 10mm
 Schraube #6-32 10mm
 Vite #6-32 10 mm
 Parafuso #6-32 10mm

**x6**

Screw #6-32 6mm
 Tornillo #6-32 6mm
 Vis #6-32 6mm
 Schraube #6-32 6mm
 Vite #6-32 6 mm
 Parafuso #6-32 6mm

**x1**

Slot cover
 Tapa de la ranura
 Couvercle de la fente
 Abdeckung des Schlitzes
 Coperchio della fessura
 Tampa da ranhura

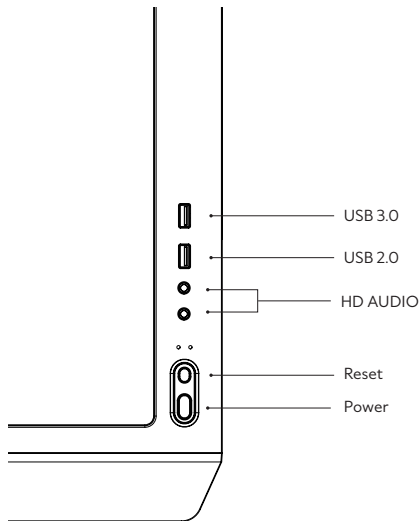

case AzaliaHD Audio connector



case USB connector



case USB3.0 connector (Optional)



Motherboard HD Audio connector

PORT1L	■	AUD GND
PORT1R	■	PRESENSE#
PORT2R	■	SENSE1 RETURN
SENSE SEND	■	NO PIN
PORT2L	■	SENSE RETURN

Motherboard USB connector

VCC	■	VCC
D-	■	D-
D+	■	D+
GND	■	GND
	■	NC

Motherboard USB3,0 connector



H.D.D LED

(GND)

+P LED

-P LED

(GND)

POWER SW

(GND)

A

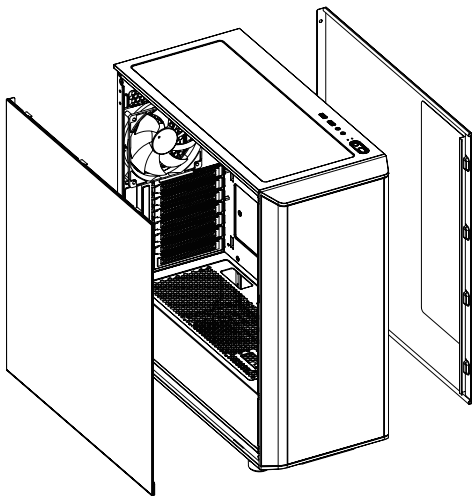

Please remove the side panels before disassembling the front panel

Retire los paneles laterales antes de desmontar el panel frontal.

Veuillez retirer les panneaux latéraux avant de démonter le panneau avant.

Bitte entfernen Sie die Seitenteile, bevor Sie die Frontplatte demontieren.

Rimuovere i pannelli laterali prima di smontare il pannello frontale.

Retire os painéis laterais antes de desmontar o painel frontal

B

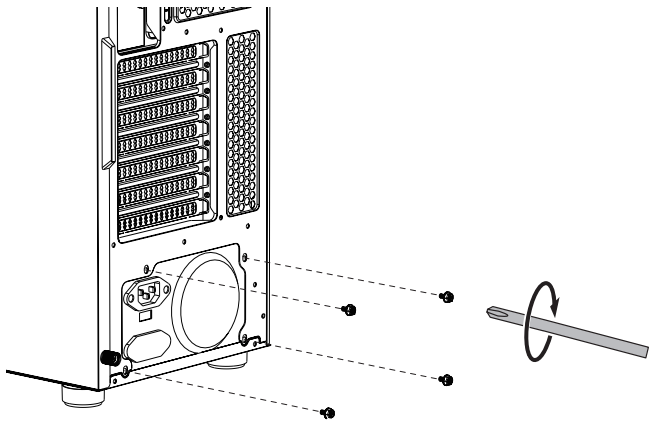

Make sure the power supply hole is aligned with the cooling vents of the chassis

Asegúrese de que el orificio de la fuente de alimentación está alineado con las rejillas de ventilación del chasis.

Assurez-vous que l'orifice du bloc d'alimentation est aligné avec les orifices de refroidissement du châssis.

Vergewissern Sie sich, dass die Öffnung des Netzteils mit den Kühlungsöffnungen des Gehäuses ausgerichtet ist.

Assicurarsi che il foro dell'alimentatore sia allineato con le prese d'aria del telaio.

Certifique-se de que o orifício da fonte de alimentação está alinhado com as aberturas de refrigeração do chasis

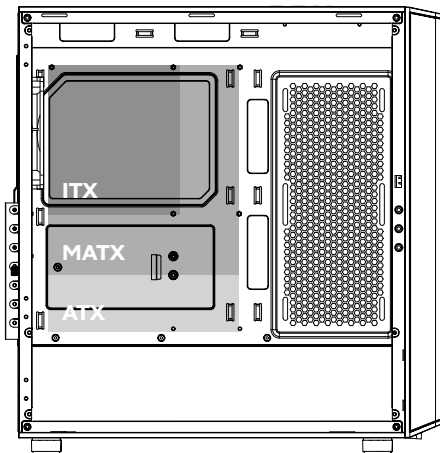

Aims the motherboard at the copper cylinder and fix with screw "M3 5mm".
If the copper pillar drops off please fix it with screw "#6-32 6.5mm" copper cylinder.

Apunte la placa base al cilindro de cobre y fijelo con tornillo "M3 5mm".
Si el pilar de cobre se cae, fijelo con el tornillo "#6-32 6.5mm" cilindro de cobre.

Visez la carte mère sur le cylindre de cuivre et fixez-la avec la vis "M3 5mm".
Si le pilier en cuivre tombe, fixez-le avec la vis "#6-32 6.5mm" cylindre en cuivre.

Richten Sie die Hauptplatine am Kupferzylinder aus und befestigen Sie sie mit der Schraube "M3 5mm".
Wenn die Kupfersäule abfällt, befestigen Sie sie mit der Schraube "#6-32 6.5mm" Kupferzylinder.

Puntare la scheda madre sul cilindro di rame e fissarla con la vite "M3 5mm".
Se la colonna di rame si stacca, fissarla con la vite "#6-32 6,5 mm" del cilindro di rame.

Apontar a placa-mãe para o cilindro de cobre e fixar com o parafuso "M3 5mm".
Se o pilar de cobre cair, fixe-o com o parafuso "#6-32 6.5mm" do cilindro de cobre.

D

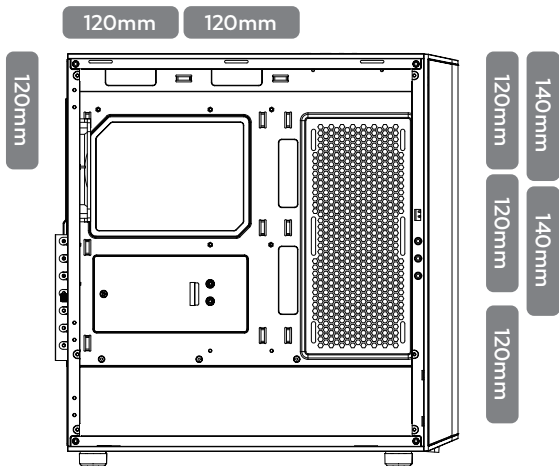

Install fan and radiator, PSU cover support 120mm*2 fans

Instale el ventilador y el radiador, la cubierta de la PSU soporta ventiladores de 120mm*2

Installer le ventilateur et le radiateur,
le couvercle du PSU supporte les ventilateurs 120mm*2

Lüfter und Kühler installieren, PSU-Abdeckung unterstützt 120mm*2 Lüfter

Installare la ventola e il radiatore,
il coperchio dell'alimentatore supporta ventole da 120 mm*2

Instale a ventoinha e o radiador, a tampa da PSU suporta ventoinhas de 120 mm*2

E

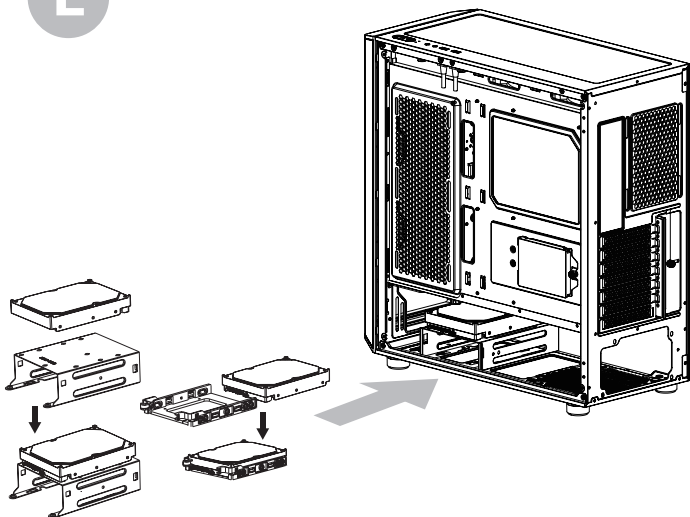

Hard disk enclosure for both SSD and HDD;
Unscrew hard disk enclosure and install HDD with screws

Carcasa de disco duro para SSD y HDD;
Desatornille la carcasa del disco duro e instale el HDD con tornillos.

Boîtier de disque dur pour SSD et HDD ;
Dévisser le boîtier du disque dur et installer le disque dur à l'aide des vis.

Festplattengehäuse für sowohl SSD als auch HDD;
Festplattengehäuse abschrauben und HDD mit Schrauben installieren

Alloggiamento del disco rigido per SSD e HDD;
Svitare l'alloggiamento del disco rigido e installare l'HDD con le viti.

Caixa do disco rígido para SSD e HDD;
Desaparafusar a caixa do disco rígido e instalar o HDD com parafusos

F

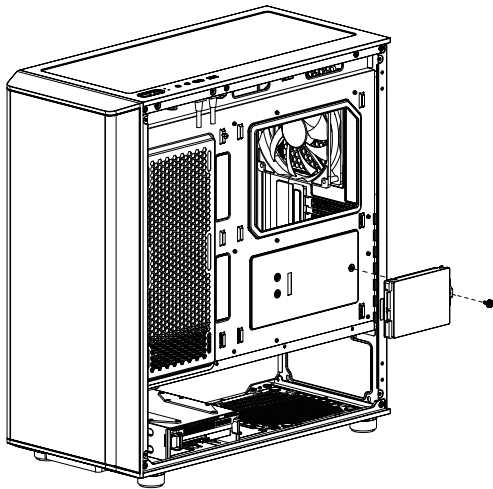

Hard disk enclosure for both SSD and HDD;
Unscrew hard disk enclosure and install HDD with screws

Carcasa de disco duro para SSD y HDD;
Desatornille la carcasa del disco duro e instale el HDD con tornillos.

Boîtier de disque dur pour SSD et HDD ;
Dévisser le boîtier du disque dur et installer le disque dur à l'aide des vis.

Festplattengehäuse für sowohl SSD als auch HDD;
Festplattengehäuse abschrauben und HDD mit Schrauben installieren

Alloggiamento del disco rigido per SSD e HDD;
Svitare l'alloggiamento del disco rigido e installare l'HDD con le viti.

Caixa do disco rígido para SSD e HDD;
Desaparafusar a caixa do disco rígido e instalar o HDD com parafusos

G

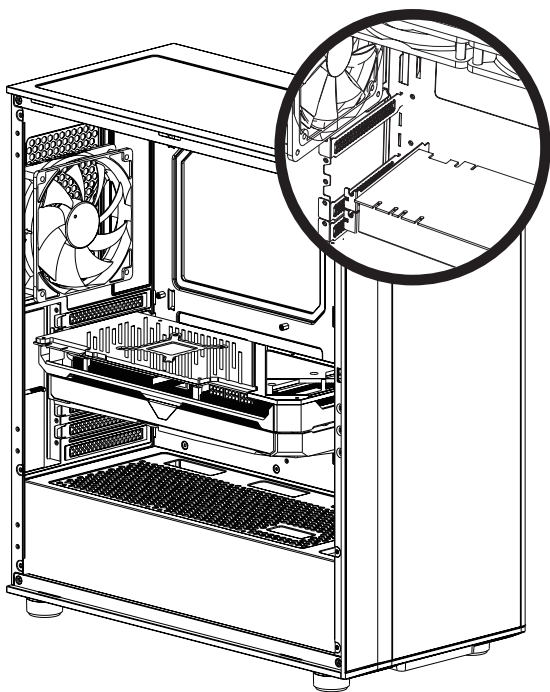

Remove the baffle marked in the picture, make sure the VGA card aims at the motherboard slot and then fix VGA card and case with "#6-32 6mm"screw. VGA card bracket is eqipped, which can be adjusted according to VGA card location.

Retire el deflector marcado en la imagen, asegúrese de que la tarjeta VGA apunta a la ranura de la placa base y, a continuación, fije la tarjeta VGA y la carcasa con un tornillo "#6-32 6mm".

El soporte de la tarjeta VGA está equipado, que se puede ajustar de acuerdo a la ubicación de la tarjeta VGA.

Retirez le déflecteur indiqué sur l'image, assurez-vous que la carte VGA est orientée vers la fente de la carte mère, puis fixez la carte VGA et le boîtier à l'aide d'une vis "#6-32 6mm".

Le support de la carte VGA est équipé et peut être ajusté en fonction de l'emplacement de la carte VGA.

Entfernen Sie die in der Abbildung markierte Blende, stellen Sie sicher, dass die VGA-Karte auf den Motherboard-Steckplatz ausgerichtet ist, und befestigen Sie dann die VGA-Karte und das Gehäuse mit der Schraube "#6-32 6mm".

Die mitgelieferte VGA-Kartenhalterung kann je nach Position der VGA-Karte angepasst werden.

Rimuovere il deflettore contrassegnato nell'immagine, assicurarsi che la scheda VGA sia orientata verso lo slot della scheda madre e fissare la scheda VGA e il case con una vite "#6-32 6mm".

La staffa della scheda VGA è in dotazione e può essere regolata in base alla posizione della scheda VGA.

Remove o deflector marcado na imagem, certifique-se de que a placa VGA aponta para a ranhura da placa-mãe e, em seguida, fixe a placa VGA e a caixa com o parafuso "#6-32 6mm".

O suporte da placa VGA está equipado, podendo ser ajustado de acordo com a localização da placa VGA.



FORT

more information at: www.tempestofficial.com

